

Community Solar Energy Pilot Program Application Form

Section A: Application Form Requirements, Instructions, Terms and Conditions

The following Application Form is intended only for entities submitting a community solar project for consideration by the New Jersey Board of Public Utilities (“Board” or “BPU”). Projects selected by the Board will be approved for participation in the Community Solar Energy Pilot Program, pursuant to the rules at N.J.A.C. 14:8-9.

This Application Form is valid only for the following Program Year and Application Period:

Program Year 1, Application Period 1

Application Period Opens: April 9, 2019 at 9:00 A.M.

Application Period Closes: September 9, 2019 at 5:00 P.M.

I. Minimum Qualification Requirements

The Community Solar Energy Pilot Program is open to projects that meet the following minimum requirements, and the full requirements defined in N.J.A.C. 14:8-9 (available for reference at the following link: [http://njcleanenergy.com/files/file/R_2019%20d_021%20\(51%20N_J_R_%20232\(a\)\).pdf](http://njcleanenergy.com/files/file/R_2019%20d_021%20(51%20N_J_R_%20232(a)).pdf)).

1. The proposed community solar project must be located in the electric service territory of an Electric Distribution Company (“EDC”) in the State of New Jersey.
2. Existing solar projects may not apply to requalify as a community solar project. An existing solar project, [REDACTED] N.J.A.C. 14:8-9.2, may not be in operation and/or been approved by the Board for connection to the distribution system prior to February 19, 2019. Projects having received a subsection (t) conditional certification from the Board prior to February 19, 2019 should refer to section B. XIII. Special Authorizations and Exemptions for additional information.
3. The Board will not consider Applications for EDCs to develop, own, or operate community solar project(s).
4. The Board will not consider Applications for projects sited on preserved farmland, as defined in N.J.A.C. 14:8-9.2.
5. The Board will not consider Applications for projects exceeding the capacity limit for individual community solar projects, set at 5 MW as defined in N.J.A.C. 14:8-9.4(g).

II. Instructions for Completing the Community Solar Energy Pilot Program Application Form

1. Each solar project applying to participate in the Community Solar Energy Pilot Program requires the submission of an individual Application Form. Do not apply for more than one (1) project per Application Form. There is no limit to the number of Application Forms that can be submitted by any one Applicant (see the definition of an “Applicant” in section A. III. Terms and Conditions).



2. Complete sections B and C, and Appendix A in full. All questions are required to be answered, unless explicitly marked as optional. All attachments are required, unless explicitly marked as optional. All attachments must be attached to the end of the Application Form, therefore forming a complete application package. Note that attachments marked as optional will be considered if included, but their absence will not penalize an Application.
3. Original signatures on all forms and certifications of this Application Form are required. The certifications contained in section C must be notarized.
4. Specific exemptions are identified throughout the Application Form which apply only if: 1) the Applicant is a government entity (municipal, county, or state), AND 2) the community solar developer will be selected by the Applicant via a Request for Proposals (“RFP”), Request for Quotations (“RFQ”), or other bidding process. If this is the case, the Applicant must include a letter describing the proposed bidding process, and the Applicant should complete all sections of the Application Form based on the project as it will be designed in the bidding process. The Applicant must further commit to issuing said RFP, RFQ, or other bidding process within 90 days of the proposed project being approved by the Board for participation in the Community Solar Energy Pilot Program (see section B. XIII. Special Authorizations and Exemptions).

III. Terms and Conditions

General Terms and Conditions

1. The “Applicant” is defined as the entity that submits the Community Solar Energy Pilot Program Application Form (for example, an Applicant may be a project developer, project owner, project operator, property owner, contractor, installer, or agent thereof).
2. Prior to completing the Application Form, the Applicant must carefully review the rules at N.J.A.C. 14:8-9, and any other rules, regulations, and codes applicable to the design, construction, and operation of a community solar project in New Jersey. It must be in compliance with all local, state and federal rules, regulations and laws. Furthermore, submission of an Application Form does not obviate the need for compliance with all applicable local, state, and federal laws and regulations at any time during the design, construction, operation, and decommissioning of a community solar project including, but not limited to, regulations by commissions such as the New Jersey Highlands Council and the New Jersey Pinelands Commission.
3. By submitting an Application, the Applicant acknowledges notice on behalf of all project participants that the information included in the Application is subject to disclosure under the Open Public Records Act, N.J.S.A. 47:1A-1 et seq. Aggregated information may be used by the Board and/or other state, federal, county, regional or local agencies in reports and evaluations, and the geographic location may be used to update Geographic Information System (“GIS”) mapping. Applicants may identify sensitive and trade secret information that they wish to keep confidential by submitting them in accordance with the confidentiality procedures set forth in



N.J.A.C. 14:1-12.3. Furthermore, the Applicant understands that the list of approved community solar projects will be published on the Board of Public Utilities website.

4. Amendments or supplements to the Community Solar Energy Pilot Program Application Form will be made available via the New Jersey Clean Energy Program (“NJCEP”) website at www.njcleanenergy.com. This Application Form may be modified for future Application Periods at any time without prior notification.

Evaluation of Applications and Approval of Projects

5. Only Applications that are administratively complete by the close of the Application Period will be considered for participation in the Community Solar Energy Pilot Program during that Program Year. An application will be deemed administratively complete if: 1) All questions are completed, except those explicitly marked as optional, 2) All required attachments are included (see Appendix B for a checklist of required attachments), and 3) All required signatures are included. Applicants will be notified if an Application is deemed administratively incomplete. An incomplete Application may be amended and resubmitted during the following Application Period with no penalty or disadvantage.
6. The Applicant may be required to supplement the information provided in the Application Form upon request from the Board or Board Staff.
7. Following the close of the Application Period, each Application will be reviewed and evaluated by a dedicated Evaluation Committee.
8. In reviewing each application, Board Staff may consult with the New Jersey Department of Environmental Protection (“NJDEP”), the New Jersey Department of Agriculture, or other state agencies as are relevant to the application. Information marked and submitted as confidential will be treated as such by the receiving agency, and used for the sole purpose of evaluation.
9. The criteria for evaluation of Applications are presented in Appendix C (Evaluation Criteria). Projects must score a minimum 30 points total in order to be considered for participation in the Community Solar Energy Pilot Program. Projects that score above 30 points will be presented to the Board for approval for participation in the Community Solar Energy Pilot Program in order, starting with the highest-scoring project and proceeding to the lowest-scoring project, and until the allocated program capacity for that Program Year is filled.
The allocated program capacity for Program Year 1 is 75 MW. At least 40% of program capacity (i.e. at least 30 MW) will be allocated to LMI projects.
10. Board Staff may reject Applications that are incomplete at the close of the Application Period, that are not in compliance with the rules and regulations established in N.J.A.C. 14:8-9, or that do not meet a minimum standard for selection, as set forth in this Application Form.

Milestones and Follow-Up for Approved Projects

11. Should the proposed community solar project be approved by the Board for participation in the Community Solar Energy Pilot Program, such approval will be contingent on the project being constructed and operated as was proposed in its Application.

Furthermore, pursuant to the rules at N.J.A.C. 14:8-9.3(c), approved projects are expected to begin construction within 6 months of their approval by the Board, and are expected to become fully operational within 12 months of their approval by the Board. Extensions may be granted by Board Staff at its discretion, based on its assessment of the specific circumstances of each project approved.

In order to monitor compliance, approved projects will be required to submit updates to the Board:

- a. Prior to the beginning of construction, the Applicant must provide evidence that commitments in the following categories have been met: project location, community and environmental justice engagement, other benefits.
- b. Prior to applying for permission to operate (“PTO”), the Applicant must provide [REDACTED] commitments in the following categories have been met: siting (other than location), all permits received.
- c. Prior to applying to the EDC for allocation of bill credits, the Applicant must provide evidence that commitments in the following categories have been met: product offering, subscriber type, geographic limit within EDC service territory.

If the approved project fails to be completed as proposed in the Application, and the Applicant fails to remediate the failure or provide an equivalent modification within a reasonable timeframe, [REDACTED] may be penalized up to [REDACTED] of the permission to operate in the Community Solar Energy Pilot Program.

Special Considerations for Project Siting

12. Unless the proposed community solar facility is located on a rooftop, parking lot, or parking structure, the Applicant must meet with the NJDEP’s Office of Permit Coordination and Environmental Review (“PCER”) to determine what permits may be required and to identify other potential issues. More information is available at: <http://www.nj.gov/dep/pcer>. The Applicant must have completed the NJDEP Permit Readiness Checklist and submitted said Checklist to NJDEP PCER prior to submitting the Application to the Board (see section B. VIII. Permits). The Permit Readiness Checklist is available at the following link: <https://www.nj.gov/dep/pcer/introchecklist.htm>.

13. Special attention should be paid when siting a project on a landfill, a brownfield, or an area of historic fill. For reference, NJDEP’s *Guidance for Installation of Solar Renewable Energy Systems on Landfills in New Jersey* can be found at the following link: <https://www.nj.gov/dep/dshw/swp/solarguidance.pdf>.

14. The Applicant should review the environmental compliance history at the proposed site and the various operations that were conducted there. Satisfaction of all outstanding NJDEP regulatory



compliance obligations, if applicable, will be required prior to applying for permission to operate. The Applicant should identify any outstanding compliance and enforcement issues associated with the property on which the proposed project is to be sited and resolve them accordingly before submitting the Post Construction NJDEP Compliance Form, if applicable.

- 15. If the proposed project is sited on Green Acres preserved open space, as defined in N.J.A.C. 14:8-9.2, or on land owned by NJDEP, the Applicant must receive special approval for the project from NJDEP prior to submitting the Application to the Board, and attach proof of approval to their application package (see section B. VII. Community Solar Facility Siting).

Submitting an Application

Applications must adhere to all of the following instructions for submission. Applications must be received no later than 5:00 P.M. on the date of the close of the Application Period in order to be considered.

Mail or hand-deliver the original complete Application package plus three copies of the complete Application pack [redacted]

New Jersey Board of Public Utilities
44 South Clinton Avenue, 7th Floor
Post Office Box 350
Trenton, New Jersey 08625-0350
Attn: Office of Clean Energy
Community Solar Energy Pilot Program Application Package
[redacted]

In addition, submit an electronic version of the complete Application package to both of the following email addresses: communitysolar@njcleanenergy.com and board.secretary@bpu.nj.gov.
[redacted]

Questions and Further Information

Please address all questions pertaining to the Application Form to communitysolar@njcleanenergy.com.

Additional guidance and Frequently Asked Questions will be available on the NJCEP website at: <http://njcleanenergy.com/renewable-energy/programs/community-solar>.

Section B: Community Solar Energy Project Description

Instructions: Section B must be completed in its entirety. Any attachments should be placed at the end of the Application package.

I. Applicant Contact Information

Applicant Company/Entity Name: Franklin Square Owner LLC
 First Name: Tyler Last Name: Haines
 Daytime Phone: 908-907-1315 Email: tyler.haines@fairstead.com
 Applicant Mailing Address: 250 W 55th St. 35th Fl.
 Municipality: New York County: New York Zip Code: 10019

Applicant is: Community Solar Project Owner Community Solar Developer/Facility Installer
 Property/Site Owner Subscriber Organization
 Agent (if agent, what role is represented) _____

II. Community Solar Project Owner

Project Owner Company/Entity Name (complete if known): Franklin Square Owner LLC
 First Name: John Last Name: Tatum
 Daytime Phone: _____ Email: _____
 Mailing Address: 250 W 55th St. 35th Fl.
 Municipality: New York County: New York Zip Code: 10019

III. Community Solar Developer

This section, "Community Solar Developer," is optional if: 1) the Applicant is a government entity (municipal, county, or state), AND 2) the community solar developer will be selected by the Applicant via a RFP, RFQ, or other bidding process. In all other cases, this section is required.

Developer Company Name (optional, complete if applicable): Franklin Square Owner LLC
 First Name: John Last Name: Tatum
 Daytime Phone: _____ Email: _____
 Mailing Address: 250 W 55th St. 35th Fl.
 Municipality: New York County: New York Zip Code: 10019

The proposed community solar project will be primarily built by:
 the Developer a contracted engineering, procurement and construction ("EPC") company

If the proposed community solar project will be primarily built by a contracted EPC company, complete the following (optional, complete if known):

If the EPC company information is left blank and the proposed project is approved by the Board for participation in the Community Solar Energy Pilot Program, the Applicant must inform the Board of the information below once the EPC company becomes known.

EPC Company Name (optional, complete if applicable): _____
 First Name: _____ Last Name: _____
 Daytime Phone: _____ Email: _____
 Mailing Address: _____
 Municipality: _____ County: _____ Zip Code: _____

IV. Property/Site Owner Information

Property Owner Company/Entity Name: Franklin Square Owner LLC
 First Name: John Last Name: Tatum
 Daytime Phone: _____ Email: _____
 Applicant Mailing Address: 250 W 55th St. 35th Fl.
 Municipality: New York County: New York Zip Code: 10019

V. Community Solar Subscriber Organization (optional, complete if known)

If this section, "Community Solar Subscriber Organization" is left blank and the proposed project is approved by the Board for participation in the Community Solar Energy Pilot Program, the Applicant must inform the Board of the information below once the Subscriber Organization becomes known.

Subscriber Organization Company/Entity Name (optional, complete if applicable): _____
 First Name: _____ Last Name: _____
 Daytime Phone: _____ Email: _____
 Mailing Address: _____
 Municipality: _____ County: _____ Zip Code: _____

VI. Proposed Community Solar Facility Characteristics

Community Solar Facility Size (as denominated on the PV panels):
0.0634 MW AC 0.084 MW DC

Community Solar Facility Location (Address): 301 S. Hildebrand Ave.
 Municipality: Glendora County: Camden Zip Code: 08029
 Name of Property (optional, complete if applicable): Franklin Square Village
 Property Block and Lot Number(s): Block: 1501, Lot: 6

Community Solar Site Coordinates: -75.076563 Longitude 39.837565 Latitude

Total Acreage of Property Block and Lots: 11.913 acres

Total Acreage of Community Solar Facility: 1.5 acres

Attach a delineated map of the portion of the property on which the community solar facility will be located. In the electronic submission, two copies of the delineated map should be provided: 1) as a PDF document, and 2) as a design plan in drawing file format (.dwg) or as a shapefile (.shp), in order to facilitate integration with Geographic Information System (GIS) software.

EDC electric service territory in which the proposed community solar facility is located: *(select one)*

- Atlantic City Electric Jersey Central Power & Light
 Public Service Electric & Gas Rockland Electric Co.

Estimated date of project completion* *(The Applicant should provide a good faith estimate of the date of project completion; however, this data is being collected for informational purposes only.):* August
 (month) 2020 [REDACTED]

Project completion is defined pursuant to the definition at N.J.A.C. 14:8-9.3 as being fully operational, up to and including having subscribers receive bill credits for their subscription to the project.

The proposed community solar facility is an existing project* Yes No

If "Yes," the Application will not be considered by the Board. See section B. XIII. for special provisions for projects having received a subsection (t) conditional certification from the Board prior to February 19, 2019. [REDACTED]

*Existing project is defined in N.J.A.C. 14:8-9.2 as a solar project having begun operation and/or been approved by the Board for connection to the distribution system prior to February 19, 2019. [REDACTED]

VII. Community Solar Facility Siting

1. The proposed community solar project has site control* Yes No

If "Yes," attach proof of site control.

If "No," the Application will be deemed incomplete.

*Site control is defined as property ownership or option to purchase, signed lease or option to lease, or signed contract for use as a community solar site or option to contract for use as a community solar site.

2. The proposed community solar facility is located, in part or in whole, on preserved farmland* Yes No

..... Yes No

If "Yes," the Application will not be considered by the Board.



*Preserved farmland is defined in N.J.A.C. 14:8-9.2 as land from which a permanent development easement was conveyed and a deed of easement was recorded with the county clerk's office pursuant to N.J.S.A. 4:1C-11 et seq.; land subject to a farmland preservation program agreement recorded with the county clerk's office pursuant to N.J.S.A. 4:1C-24; land from which development potential has been transferred pursuant to N.J.S.A. 40:55D-113 et seq. or N.J.S.A. 40:55D-137 et seq.; or land conveyed or dedicated by agricultural restriction pursuant to N.J.S.A. 40:55D-39.1.

3. The proposed community solar facility is located, in part or in whole, on Green Acres preserved open space* or on land owned by the New Jersey Department of Environmental Protection (NJDEP) Yes No

If "Yes," the Applicant must attach special authorization from NJDEP for the site to host a community solar facility. The Board will not consider Applications for projects located, in part or in whole, on Green Acres preserved open space or on land owned by NJDEP, unless the Applicant has received special authorization from NJDEP and includes proof of such special authorization in the Application package.

*Green [redacted] open space is defined [redacted] and classified as either "funded parkland" or "unfunded parkland" under N.J.A.C. 7:36, or land purchased by the State with "Green Acres funding" (as defined at N.J.A.C. 7:36).

4. The proposed community solar facility is located, in part or in whole, on land located in the New Jersey Highlands Planning Area or Preservation Area Yes No

5. The proposed community solar facility is located, in part or in whole, on land located in the New Jersey Pinelands Yes No

6. The proposed community solar facility is located, in part or in whole, [redacted] actively devoted to agricultural or horticultural use and that is/has been valued, assessed, and taxed pursuant to the "Farmland Assessment Act of 1964," P.L. 1964, c.48 (C. 54:4-23.1 et seq.) at any time within the ten year period prior to the date of submission of the Application Yes No

7. The proposed community solar facility is located, in part or in whole, on a landfill Yes No
 If "Yes," provide the name of the landfill, as identified in NJDEP's database of New Jersey landfills, available at www.nj.gov/dep/dshw/lrm/landfill.htm: _____

8. The proposed community solar facility is located, in part or in whole, on a brownfield Yes No
 If "Yes," has a final remediation document been issued for the property? Yes No



If "Yes," attach a copy of the Response Action Outcome ("RAO") issued by the LSRP or the No Further Action ("NFA") letter issued by NJDEP.

- 9. The proposed community solar facility is located, in part or in whole, on an area of historic fill Yes No
 If "Yes," have the remedial investigation requirements pursuant to the Technical Requirements for Site Remediation, N.J.A.C. 7:26E-4.7 been implemented? Yes No
 Has the remediation of the historic fill been completed pursuant to the Technical Requirements for Site Remediation, N.J.A.C. 7:26E-5.4? Yes No
 If the remediation of the historic fill has been completed, attach a copy of the Response Action Outcome ("RAO") issued by a Licensed Site Remediation Professional ("LSRP") or the No Further Action ("NFA") letter issued by NJDEP.

- 10. The proposed community solar facility is located on a parking lot Yes No

- 11. The proposed community solar facility is located on a parking deck Yes No
 [REDACTED]

- 12. The proposed community solar facility is located on a rooftop Yes No

- 13. The proposed community solar facility is located on a canopy over an impervious surface (e.g. walkway) Yes No

- 14. The proposed community solar facility is located on the roof of an affordable housing building or complex Yes No
 [REDACTED]

- 15. The proposed community solar facility is located on a water reservoir or other water body ("floating solar") Yes No
 [REDACTED]

- 16. The proposed community solar facility is located on an area designated in need of redevelopment Yes No
 If "Yes," attach proof of the designation of the area as being in need of redevelopment from a municipal, county, or state entity.

- 17. The proposed community solar facility is located on land or a building that is preserved by a municipal, county, state, or federal entity Yes No
 If "Yes," attach proof of the designation of the area as "preserved" from a municipal, county, or state entity.

- 18. The proposed community solar facility is located, in part or in whole, on forested lands Yes No



Construction of the proposed community solar facility will require cutting down one or more trees Yes No
If "Yes," estimated number of trees required to be cut for construction: _____

19. The proposed community solar facility is located on land or a building owned or controlled by a government entity, including, but not limited to, a municipal, county, state, or federal entity Yes No

20. Are there any use restrictions at the site? Yes No
If "Yes," explain the use restriction below and provide documentation that the proposed community solar project is not prohibited.

Will the [redacted] be required to be modified [redacted] Yes No
If "Yes," explain the modification below.

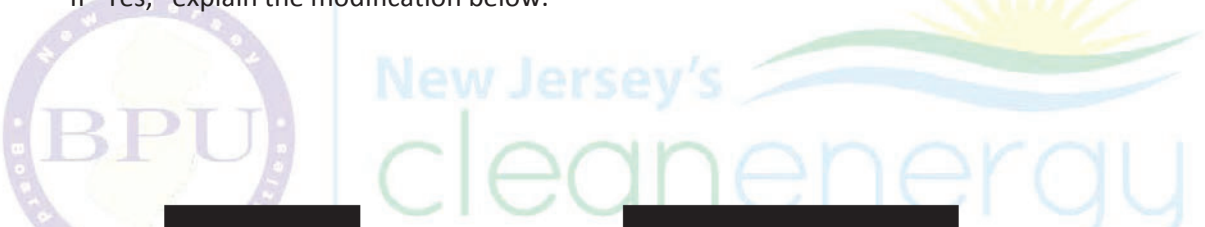

21. The proposed community solar facility has been specifically designed or planned to preserve or enhance the site (e.g. landscaping, land enhancements, pollination support, stormwater management, soil conservation, etc.) Yes No
If "Yes," explain below, and provide any additional documentation in an attachment [redacted]

VIII. Permits

1. The Applicant has completed NJDEP Permit Readiness Checklist, and submitted it to NJDEP's PCER Yes No
If "Yes," attach a copy of the completed Permit Readiness Checklist as it was submitted to NJDEP PCER.



If “No,” the Application will be deemed incomplete. Exception: Applications for community solar projects located on a rooftop, parking lot, or parking structure are exempt from this requirement.

2. The Applicant has met with NJDEP’s PCER Yes No

If “Yes,” attach proof of a meeting with NJDEP PCER.

If “No,” the Application will be deemed incomplete. Exception: Applications for community solar projects located on a rooftop, parking lot, or parking structure are exempt from this requirement.

3. Please list all permits, approvals, or other authorizations that will be needed for the construction and operation of the proposed community solar facility pursuant to local, state and federal laws and regulations. Include permits that have already been received, have been applied for, and that will need to be applied for. The Applicant may extend this table by attaching additional pages if necessary. These include:

- a. Permits, approvals, or other authorizations from NJDEP (i.e. Land Use, Air Quality, New Jersey Discharge Elimination) the property.
- b. Permits, approvals, or other authorizations from NJDEP (i.e. Land Use, Air Quality, NJPDES, etc.) directly related to the installation and operation of a solar facility on this property.
- c. Permits, approvals, or other authorizations other than those from NJDEP for the development, construction, or operation of the community solar facility (including local zoning and other local and state permits)

An Application that does not list all permits, approvals, or other authorizations that will be needed for the construction and operation of the proposed community solar facility will be deemed incomplete.

If a permit has been received, attach a copy of the permit. _____

Permit Name & Description	Permitting Agency/Entity	Date Permit Applied for (if applicable) / Date Permit Received (if applicable)
Building	Gloucester Township	TBD
Electrical	Gloucester	TBD



4. The Applicant has consulted the hosting capacity map of the relevant EDC and determined that, based on the capacity hosting map as published at the date of submission of the Application, there is sufficient capacity available at the proposed location to build the proposed community solar facility Yes No
 If "Yes," include a screenshot of the capacity hosting map at the proposed location, showing the available capacity.
 If "No," the Application will be deemed incomplete.

IX. Community Solar Subscriptions and Subscribers

1. Estimated or Anticipated Number of Subscribers (please provide a good faith estimate or range):
 8 _____

2. Estimated or Anticipated Breakdown of Subscribers (please provide a good faith estimate or range of the kWh of project allocated to each category):
 Residential: 8 _____ Commercial: _____
 Industrial: _____ Other: _____ (define "other": _____)

3. The proposed community solar project is an LMI project* Yes No
 *An LMI project is defined pursuant to N.J.A.C. 14:8-9 as a community solar project in which a minimum 51 percent of project capacity is subscribed by LMI subscribers. _____

4. The proposed community solar project will allocate at least 51% of project capacity to residential customers Yes No

5. The proposed community solar project is being developed in partnership with an affordable housing provider: Yes No
 If "Yes," attach a letter of support from the affordable housing provider.

6. An affordable housing provider is seeking to qualify as an LMI subscriber for the purposes of the community solar project Yes No
 If "Yes," estimated or anticipated percentage of the project capacity for the affordable housing provider's subscription (provide an estimate or range): _____

If "Yes," what specific, substantial, identifiable, and quantifiable long-term benefits from the community solar subscription are being passed through to their residents/tenants?



Additionally, the affordable housing provider must attach a signed affidavit that the specific, substantial, identifiable, and quantifiable long-term benefits from the community solar subscription will be passed through to their residents/tenants.

7. This project uses an anchor subscriber (*optional*) Yes No

If "Yes," name of the anchor subscriber (*optional*): _____

Estimated or anticipated percentage or range of the project capacity for the anchor subscriber's subscription: _____

8. Is there any expectation that the account holder of a master meter will subscribe to the community solar project on behalf of its tenants? Yes No

If "Yes," [redacted] identifiable, sufficient [redacted] s from the community solar subscription are being passed through to the tenants?

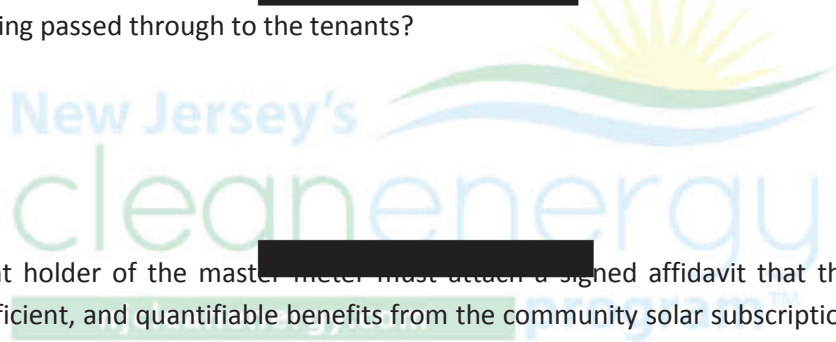

Additionally, the account holder of the master meter must attach a signed affidavit that the specific, identifiable, sufficient, and quantifiable benefits from the community solar subscription will be passed through to the tenants.

If "No," please be aware that, if, at any time during the operating life of the community solar project the account holder of a master meter wishes to subscribe to the community solar project on behalf of its tenants, it must submit to the Board a signed affidavit that the specific, identifiable, sufficient, and quantifiable benefits from the community solar subscription will be passed through to its tenants.

9. The geographic restriction for distance between project site and subscribers is: (*select one*)

- No geographic restriction: whole EDC service territory
- Same county OR same county and adjacent counties
- Same municipality OR same municipality and adjacent municipalities

Note: The geographic restriction selected here will apply for the lifetime of the project, barring special dispensation from the Board, pursuant to N.J.A.C. 14:8-9.5(a).



10. Product Offering: *(The Applicant must also complete and attach one or more product offering form(s) found in Appendix A. See Appendix A for exemptions.)*

The subscription proposed offers guaranteed or fixed savings to subscribers Yes No

If "Yes," the guaranteed or fixed savings are offered as:

- A percentage saving on the customer's annual electric utility bill
- A percentage saving on the customer's community solar bill credit
- Other: _____

If "Yes," the proposed savings represent:

- 0% - 5% of the customer's annual electric utility bill or bill credit
- 5% - 10% of the customer's annual electric utility bill or bill credit
- 10% - 20% of the customer's annual electric utility bill or bill credit
- over 20% of the customer's annual electric utility bill or bill credit

The subscription proposed offers subscribers ownership or a pathway to ownership of a share of the community solar facility Yes No

If "Yes," include proof of a pathway to ownership of a share of the community solar facility offered to the subscribers in Appendix A.

11. The list of approved community solar projects will be published on the Board's website. Additionally, subscriber organizations have the option of indicating, on this list, that the project is currently seeking subscribers.

If this project is currently seeking subscribers, the Board should indicate on the project's website that the project is currently seeking subscribers Yes No

If "Yes," the contact information indicated on the Board's website should read:

Company/Entity Name: _____ Contact Name: _____
 Daytime Phone: _____ Email: _____

Note: it is the responsibility of the project's subscriber organization to notify the Board if/when the project is no longer seeking subscribers, and request that the Board remove the above information on its website.

X. Community Engagement

1. The proposed community solar project is being developed by or in collaboration* with the municipality in which the project is located Yes No

If "Yes," explain how and attach a letter of support from the municipality in which the project is located.

*Collaboration with the municipality should include, at minimum, one or more meetings with relevant municipal authorities and clear evidence of municipal involvement and approval of the design, development, or operation of the proposed community solar project.

2. The proposed community solar project is being developed in collaboration* with one or more local community organization(s) Yes No

If "Yes," explain how and attach a letter of support from the local community organization(s).

*Collaboration with a local community organization should include, at minimum, one or more meetings with the relevant local community organization(s) and clear evidence of the local community organization's involvement and approval of the design, development, or operation of the proposed community solar project.

[Redacted]

[Redacted]

3. The proposed community solar project was developed, at least in part, through a community consultative process* Yes No

If "Yes," please describe the consultative process.

*A community consultative process should include, at minimum, one or more opportunities for public intervention and outreach to the municipality and/or local community organizations.

[Redacted]

[Redacted]

[Redacted]

XI. Project Cost

1. Provide the following cost estimates and attach substantiating evidence in the form of charts and/or spreadsheet models:

Applicants are expected to provide a good faith estimate of costs associated with the proposed community solar project, as they are known at the time the Application is filed with the Board. This information will not be used in the evaluation of the proposed community solar project.

Net Installed Cost (in \$)	[Redacted]
Net Installed Cost (in \$/Watt)	[Redacted]
Initial Customer Acquisition Cost (in \$/Watt)	[Redacted]
Annual Customer Churn Rate (in %)	[Redacted]

Annual Operating Expenses (in c/kWh)	█
LCOE (in c/kWh)	█

2. Pursuant to N.J.A.C. 14:8-9.7(q), “community solar projects shall be eligible to apply, via a one-time election prior to the delivery of any energy from the facility, for SRECs or Class I RECs, as applicable, or to any subsequent compensations as determined by the Board pursuant to the Clean Energy Act.”

For indicative purposes only, please indicate all local, state and federal tax incentives which will be applied to if the proposed community solar project is approved for participation in the Community Solar Energy Pilot Program:

Investment Tax Credit (ITC) and Low-Income Housing Tax Credit (LIHTC).

XII. Other Benefits

1. The proposed community solar facility is paired with another distributed energy resource:
 - a. Micro-grid project Yes No
 - b. Storage Yes No
 - c. Other (identify): _____ Yes No
2. The proposed community solar facility provides grid benefits (e.g. congestion reduction) Yes No
 If “Yes” to any, please explain how and provide supporting documents.
 Congestion reduction and improved grid resiliency resulting from the deployment of DG at points of interconnection that can accept input load.
4. The proposed community solar project will create temporary or permanent jobs in New Jersey Yes No
 If “Yes,” estimated number of temporary jobs created in New Jersey: 5
 If “Yes,” estimated number of permanent jobs created in New Jersey: _____
5. The proposed community solar project will provide job training opportunities for local solar trainees Yes No
 If “Yes,” will the job training be provided through a registered apprenticeship? Yes No



If "Yes," identify the entity or entities through which job training is or will be organized (e.g. New Jersey GAINS program, partnership with local school):

XIII. Special Authorizations and Exemptions

1. Is the proposed community solar project co-located with another community solar facility (as defined at N.J.A.C. 14:8-9.2)? Yes No
 If "Yes," please explain why the co-location can be approved by the Board, consistent with the provisions at N.J.A.C. 14:8-9.

2. Does this project seek an exemption from the 10-subscriber minimum? Yes No
 If "Yes," [redacted] rate below (and attach [redacted] relevant):

- a. That the project is sited on the property of a multi-family building.
- b. That the project will provide specific, identifiable, and quantifiable benefits to the households residing in said multi-family building.
- a. Yes, the project is located on the rooftops of affordable housing buildings.
- b. The 6 (POIs) collocated systems combine to form a 340 kW PV system providing direct benefits to the LMI residents on site. Reducing the number of POIs would allow the system to meet the 10-subscriber minimum but would require additional trenching, further disturbing the residents.

3. Specific sections throughout the Application Form are identified as optional only if: 1) the Applicant is a government entity (municipal, county, or state), and 2) [redacted] the community solar developer will be selected by the Applicant via a RFP, RFQ, or other bidding process. Has the Applicant left those specific sections blank? Yes No
 If "Yes," attach a letter describing the proposed bidding process. The Applicant must further commit to issuing said RFP, RFQ, or other bidding process within 90 days of the proposed project being approved by the Board for participation in the Community Solar Energy Pilot Program. The Applicant will be required to provide the information contained in those optional sections to the Board once it becomes known.

4. Has the proposed community solar project received, in part or in whole, a subsection (t) conditional certification from the Board prior to February 19, 2019? Yes No
 If "Yes," the project may apply to participate in the Community Solar Energy Pilot Program if it commits to withdrawing the applicable subsection (t) conditional certification immediately if it is approved by the Board for participation in the Community Solar Energy Pilot Program. Attach a signed affidavit that the Applicant will immediately withdraw the applicable subsection (t)

conditional certification if the proposed project is approved by the Board for participation in the Community Solar Energy Pilot Program.





Section C: Certifications

Instructions: Original signatures on all certifications are required. All certifications in this section must be notarized.

Applicant Certification

The undersigned warrants, certifies, and represents that:

- 1) I, John Tatum (name) am the Authorized Signatory (title) of the Applicant Franklin Square Owner LLC (name) and have been authorized to file this Applicant Certification on behalf of my organization; and
- 2) The information provided in this Application package has been personally examined, is true, accurate, complete, and correct to the best of the undersigned's knowledge, based on personal knowledge or on inquiry of individuals with such knowledge; and
- 3) The community solar facility proposed in the Application will be constructed, installed, and operated as described in the Application and in accordance with all Board rules and applicable laws; and
- 4) The system proposed in the Application will be constructed, installed, and operated in accordance with all Board policies and procedures for the SREC Registration Program or subsequent revision to the SREC Registration Program, if applicable; and
- 5) My organization understands that certain information in this Application is subject to disclosure under the Open Public Records Act, N.J.S.A. 47-1A-1 et seq., and that sensitive and trade secret information that they wish to keep confidential should be submitted in accordance with the confidentiality procedures set forth in N.J.A.C. 14:1-12.3.; and
- 6) My organization acknowledges that **submission of false information may be grounds for denial of this Application, and if any of the foregoing statements are willfully false, they are subject to punishment to the full extent of the law, including the possibility of fine and imprisonment.**

Signature: [Handwritten Signature] Date: 9/5/2019

Print Name: John Tatum
Title: Authorized Signatory Company: Franklin Square Owner LLC

Signed and sworn to before me on this 5th day of September, 2019

Signature: [Handwritten Signature]
Name: Jaquelyn L. Pentore

Jaquelyn L. Pentore
Notary Public, State of New York
No. 01PE6367911
Qualified in New York County
Commission Expires 12/04/2021

Project Developer Certification

This Certification "Project Developer / Installer" is optional if: 1) the Applicant is a government entity (municipal, county, or state), AND 2) the community solar developer will be selected by the Applicant via a Request for Proposals (RFP), Request for Quotations (RFQ), or other bidding process. In all other cases, this Certification is required.

The undersigned warrants, certifies, and represents that:

- 1) I, John Tatum (name) am the Authorized Signatory (title) of the Project Developer Franklin Square Owner LLC (name) and have been authorized to file this Applicant Certification on behalf of my organization; and
- 2) The information provided in this Application package has been personally examined, is true, accurate, complete, and correct to the best of the undersigned's knowledge, based on personal knowledge or on inquiry of individuals with such knowledge; and
- 3) The community solar facility proposed in the Application will be constructed, installed, and operated as described in the Application and in accordance with all Board rules and applicable laws; and
- 4) The system proposed in the Application will be constructed, installed, and operated in accordance with all Board policies and procedures for the SREC Registration Program or subsequent revision to the SREC Registration Program, if applicable; and
- 5) My organization understands that certain information in this Application is subject to disclosure under the Open Public Records Act, N.J.S.A. 47-1A-1 et seq., and that sensitive and trade secret information that they wish to keep confidential should be submitted in accordance with the confidentiality procedures set forth in N.J.A.C. 14:1-12.3.; and
- 6) My organization acknowledges that **submission of false information may be grounds for denial of this Application, and if any of the foregoing statements are willfully false, they are subject to punishment to the full extent of the law, including the possibility of fine and imprisonment.**

Signature:  Date: 9/5/2019
 Print Name: John Tatum, Authorized Signatory
 Title: _____ Company: Franklin Square Owner LLC

Signed and sworn to before me on this 5th day of September, 2019



 Signature
Jaquelyn L. Pentore
 Name

Jaquelyn L. Pentore
 Notary Public, State of New York
 No. 01PE6367911
 Qualified in New York County
 Commission Expires 12/04/2021

Project Owner Certification

The undersigned warrants, certifies, and represents that:

- 1) I, John Tatum (name) am the Authorized Signatory (title) of the Project Owner Franklin Square Owner LLC (name) and have been authorized to file this Applicant Certification on behalf of my organization; and
- 2) The information provided in this Application package has been personally examined, is true, accurate, complete, and correct to the best of the undersigned's knowledge, based on personal knowledge or on inquiry of individuals with such knowledge; and
- 3) The community solar facility proposed in the Application will be constructed, installed, and operated as described in the Application and in accordance with all Board rules and applicable laws; and
- 4) The system proposed in the Application will be constructed, installed, and operated in accordance with all Board policies and procedures for the SREC Registration Program or subsequent revision to the SREC Registration Program, if applicable; and
- 5) My organization understands that certain information in this Application is subject to disclosure under the Open Public Records Act, N.J.S.A. 47-1A-1 et seq., and that sensitive and trade secret information that they wish to keep confidential should be submitted in accordance with the confidentiality procedures set forth in N.J.A.C. 14:1-12.3.; and
- 6) My organization acknowledges that **submission of false information may be grounds for denial of this Application, and if any of the foregoing statements are willfully false, they are subject to punishment to the full extent of the law, including the possibility of fine and imprisonment.**

Signature:  Date: 9/5/2019
 Print Name: John Tatum
 Title: Authorized Signatory Company: Franklin Square Owner LLC

Signed and sworn to before me on this 5th day of September, 2019

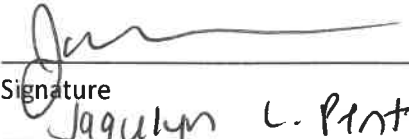

 Signature
Jaquelyn L. Pentore
 Name

Jaquelyn L. Pentore
 Notary Public, State of New York
 No. 01PE6367911
 Qualified in New York County
 Commission Expires 12/04/2021

Property Owner Certification

The undersigned warrants, certifies, and represents that:

- 1) I, John Tatum (name) am the Authorized Signatory (title) of the Property Franklin Square Owner LLC (name) and have been authorized to file this Applicant Certification on behalf of my organization; and
- 2) The information provided in this Application package pertaining to siting and location of the proposed community solar project has been personally examined, is true, accurate, complete, and correct to the best of the undersigned's knowledge, based on personal knowledge or on inquiry of individuals with such knowledge; and
- 3) My organization or I understand that certain information in this Application is subject to disclosure under the Open Public Records Act, N.J.S.A. 47-1A-1 et seq., and that sensitive and trade secret information that they wish to keep confidential should be submitted in accordance with the confidentiality procedures set forth in N.J.A.C. 14:1-12.3.; and
- 4) My organization acknowledges that **submission of false information may be grounds for denial of this Application, and if any of the foregoing statements are willfully false, they are subject to punishment to the full extent of the law, including the possibility of fine and imprisonment.**

Signature:  Date: 9/5/2019
 Print Name: John Tatum
 Title: Authorized Signatory Company: Franklin Square Owner LLC

Signed and sworn to before me on this 5th day of September, 2019

 Signature
Jaquelyn L. Pentore
 Name

Jaquelyn L. Pentore
 Notary Public, State of New York
 No. 01PE6367911
 Qualified in New York County
 Commission Expires 12/04/2021

Section D: Appendix

Appendix A: Product Offering Questionnaire

Complete the following Product Offering Questionnaire. If there are multiple different product offerings for the proposed community solar project, please complete and attach one Product Offering Questionnaire per product offering.

Applicants are expected to provide a good faith description of the product offerings developed for the proposed community solar project, as they are known at the time the Application is filed with the Board. If the proposed project is approved by the Board, the Applicant must notify the Board and receive approval from the Board for any modification or addition to a Product Offering Questionnaire.

Exception: This "Product Offering Questionnaire" is optional if: 1) the Applicant is a government entity (municipal, county, or state), AND 2) the community solar developer will be selected by the Applicant via a Request for Proposals (RFP), Request for Quotations (RFQ), or other bidding process.

This Questionnaire is Product Offering number _____ of _____ (total number of product offerings).

1. Community Solar Subscription Type (examples: kilowatt hours per year, kilowatt size, percentage of community solar facility's nameplate capacity, percentage of subscriber's historical usage, percentage of subscriber's actual usage):

2. Community Solar Subscription Price: (check all that apply)

Fixed price per month

Variable price per month, variation based on: _____

The subscription price has an escalator of _____ % every _____ (interval)

3. Contract term (length): _____ months, or _____ years OR month-to-month

4. Fees

Sign-up fee: _____

Early Termination or Cancellation fees: _____

Other fee(s) and frequency: _____

5. Does the subscription guarantee or offer fixed savings or specific, quantifiable economic benefits to the subscriber? Yes No

If "Yes," the savings are guaranteed or fixed:

- As a percentage of monthly utility bill
- As a fixed guaranteed savings compared to average historic bill
- As a fixed percentage of bill credits
- Other: _____

6. Special conditions or considerations:



Appendix B: Required Attachments Checklist

Note that this list is for indicative purposes only. Additional attachments may be required, and are identified throughout this Application Form.

Required Attachments for all Applications	Page	Attached?
Delineated map of the portion of the property on which the community solar facility will be located.	p.7	<input checked="" type="checkbox"/> Yes <input type="checkbox"/> No
For electronic submission only: copy of the delineated map of the portion of the property on which the community solar facility will be located as a PDF and in drawing file format (.dwg) or as a shapefile (.shp).	p.7	<input checked="" type="checkbox"/> Yes <input type="checkbox"/> No
Proof of site control.	p.8	<input checked="" type="checkbox"/> Yes <input type="checkbox"/> No
Copy of the completed Permit Readiness Checklist as it was submitted to NJDEP PCER, if applicable.	p.11	<input type="checkbox"/> Yes <input checked="" type="checkbox"/> No
Proof of a meeting with NJDEP PCER, if applicable.	p.12	<input type="checkbox"/> Yes <input checked="" type="checkbox"/> No
A screenshot of the capacity hosting map at the proposed location, showing the available capacity.	p.12	<input checked="" type="checkbox"/> Yes <input type="checkbox"/> No
Substantiating e [REDACTED] ct cost in the form of [REDACTED] spreadsheet models.	p.16	<input checked="" type="checkbox"/> Yes <input type="checkbox"/> No
Certifications in Section C.	p.19-23	<input checked="" type="checkbox"/> Yes <input type="checkbox"/> No
Product Offering Questionnaire(s).	p.24	<input checked="" type="checkbox"/> Yes <input type="checkbox"/> No

Required Attachments for Exemptions	Page	Attached?
The Applicant is [REDACTED] entity (municipal, county [REDACTED] community solar developer will be selected by the Applicant via a Request for Proposals (RFP), Request for Quotations (RFQ), or other bidding process: ⇒ Attach a letter from the Applicant describing the bidding process	p. 6, p.19	<input type="checkbox"/> Yes <input checked="" type="checkbox"/> No
The proposed community solar project is located, in part or in whole, on Green Acres preserved open space or on land owned by NJDEP. ⇒ Attach special authorization from NJDEP for the site to host a community solar facility.	p. [REDACTED]	<input type="checkbox"/> Yes <input checked="" type="checkbox"/> No
The proposed community solar project has received, in part or in whole, a subsection (t) conditional certification from the Board prior to February 19, 2019. ⇒ Attach a signed affidavit that the Applicant will immediately withdraw the applicable subsection (t) conditional certification if the proposed project is approved by the Board for participation in the Community Solar Energy Pilot Program.	p. 19	<input type="checkbox"/> Yes <input checked="" type="checkbox"/> No

Appendix C: Evaluation Criteria

The Evaluation Criteria chart below lists the various categories that the Board will consider in evaluating project Applications. Projects must score a minimum 30 points total in order to be considered for participation in the Community Solar Energy Pilot Program. Projects that score above 30 points will be awarded program capacity in order, starting with the highest-scoring project and proceeding to the lowest-scoring project.

Evaluation Criteria	Max. Points
Low- and Moderate-Income and Environmental Justice Inclusion Higher preference: LMI project	30
Siting Higher preference: landfills, brownfields, areas of historic fill, rooftops, parking lots, parking decks Medium preference: canopies over impervious surfaces (e.g. walkway), areas designated in need of redevelopment No Points: preserved lands, forested areas, [redacted] Bonus points for: landscaping, land enhancement, pollination support, stormwater management, soil conservation	20 Max. possible bonus points: 5
Product Offering Higher preference: guaranteed savings >10%, flexible terms* Medium preference: guaranteed savings >5% No Points: no guaranteed savings, no flexible terms* [redacted] *Flexible terms may include: no cancellation fee, short-term contract	15
Community and Environmental Justice Engagement Higher preference: partnership with municipality, partnership with local community organization(s), partnership with affordable housing provider Medium preference: letter of support from municipality, project owner is a government and/or public and/or quasi-public entity, project owner is an affordable housing developer	10 [redacted]
Subscribers Higher preference: more than 51% project capacity is allocated to residential subscribers	10
Other Benefits Higher preference: Provides local jobs/job training, demonstrates co-benefits (e.g. paired with storage, micro-grid project, energy audit, EE measures)	10
Geographic Limit within EDC service territory Higher preference: municipality/adjacent municipality Medium preference: county/adjacent county No Points: any geographic location within the EDC service territory.	5

ZONING INFORMATION

Zoning District: APT (Apartment District)
R-4 (Residential District)

Setbacks:
Front (Station Road): 75 Feet Min.
Street Side: 75 Feet Min.
Interior Side: 50 Feet Min.
Rear (South Lot Lines): 30 Feet Min.
Building Spacing: 60 Feet from the Front of Any Building to Any Other Building; 30 Feet from the Side of Any Building to Any Other Building; 60 Feet from the Rear of Any Building to Any Other Building.

Zoning Source: LETTER PROVIDED BY GLOUCESTER TOWNSHIP ZONING/PLANNING DEPT.
P2Z REPORT FOR: FRANKLIN SQUARE VILLAGE
301 SOUTH HILDEBRAND AVENUE,
GLENORA, NEW JERSEY
PREPARED FOR: FRANKLIN SQUARE OWNER LLC,
C/O FAIRSTEAD AFFORDABLE,
153 W. 57TH STREET, 36TH FLOOR,
NEW YORK, NEW YORK 10019
DATE: FINAL - 06/28/2017
REVISED - 08/08/2017
PZR SITE NUMBER: 104440-1

LIST OF POSSIBLE ENCROACHMENTS

The following list of encroachments is only the opinion of this surveyor and should not be interpreted as complete listing:

- 4 Chain Link Fence - Encroaches on Subject Property from Block 1501, Lot 1 by 0.2 feet.
Building - Encroaches on Subject Property from Block 404, Lot 9 by 1.0 ft feet.
Sheet - Encroaches on Subject Property from Block 404, Lot 8 by 1.3 feet.
Concrete Wall - Encroaches on Subject Property from Block 404, Lot 1 by 2.2 feet.
Wood Fence - Encroaches on Subject Property from Block 301, Lot 18 by 3.2 feet and 2.1 feet and 0.8 feet.

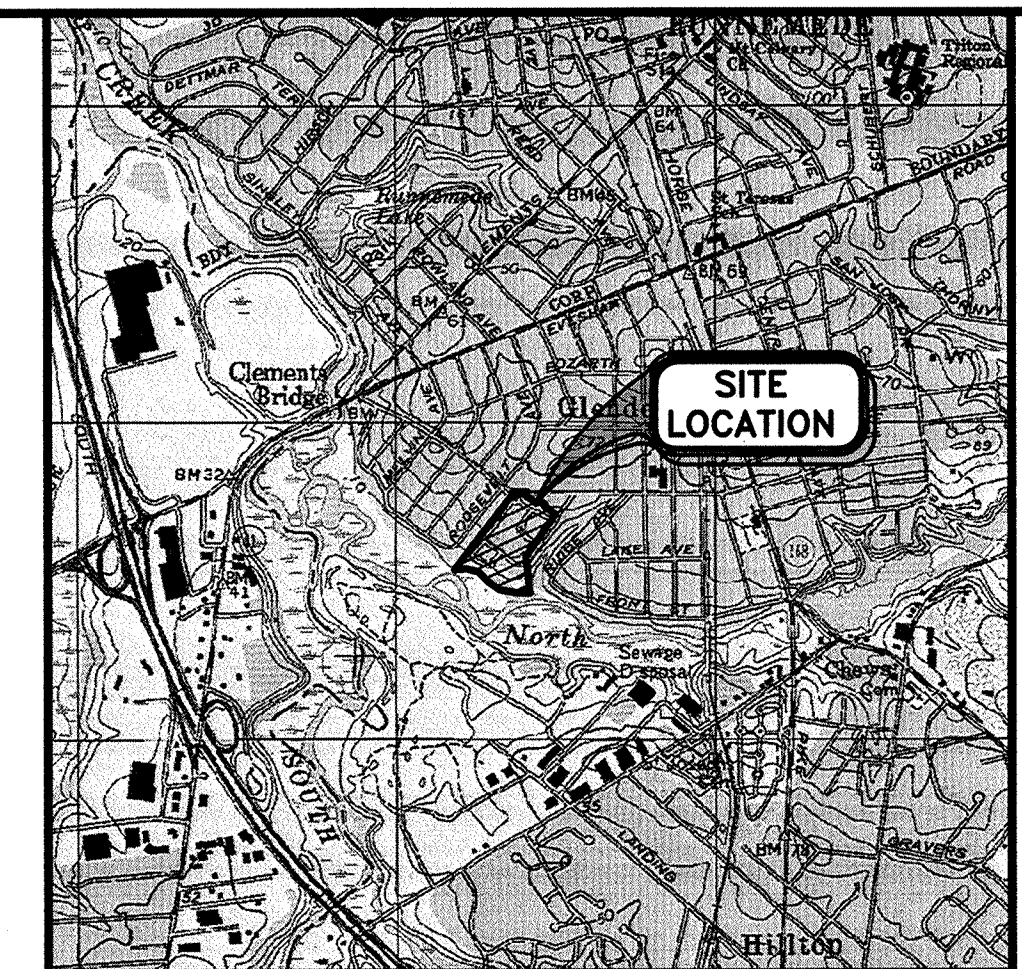

KEY MAP
SCALE: 1"=2000'

COMMITMENT FOR TITLE INSURANCE PREPARED BY FIDELITY NATIONAL TITLE INSURANCE COMPANY FOR TITLE INSURANCE COMMITMENT #19-000257NCS, EFFECTIVE DATE OF FEBRUARY 7, 2019.

SCHEDULE B - SECTION II

- 11. SUBJECT TO EASEMENT AS SET FORTH IN DEED BOOK 3076, PAGE 596. (PLOTTED)
12. SUBJECT TO EASEMENT AS SET FORTH IN DEED BOOK 3217, PAGE 1067. (APPEARS BLANKET IN NATURE - ATTACHED PLAN ILLEGIBLE)
13. SUBJECT TO WETLANDS ORDER AS SET FORTH IN DEED BOOK 3230, PAGE 800. (NO WETLANDS FOUND ON SITE PER NURSE I-MAP)

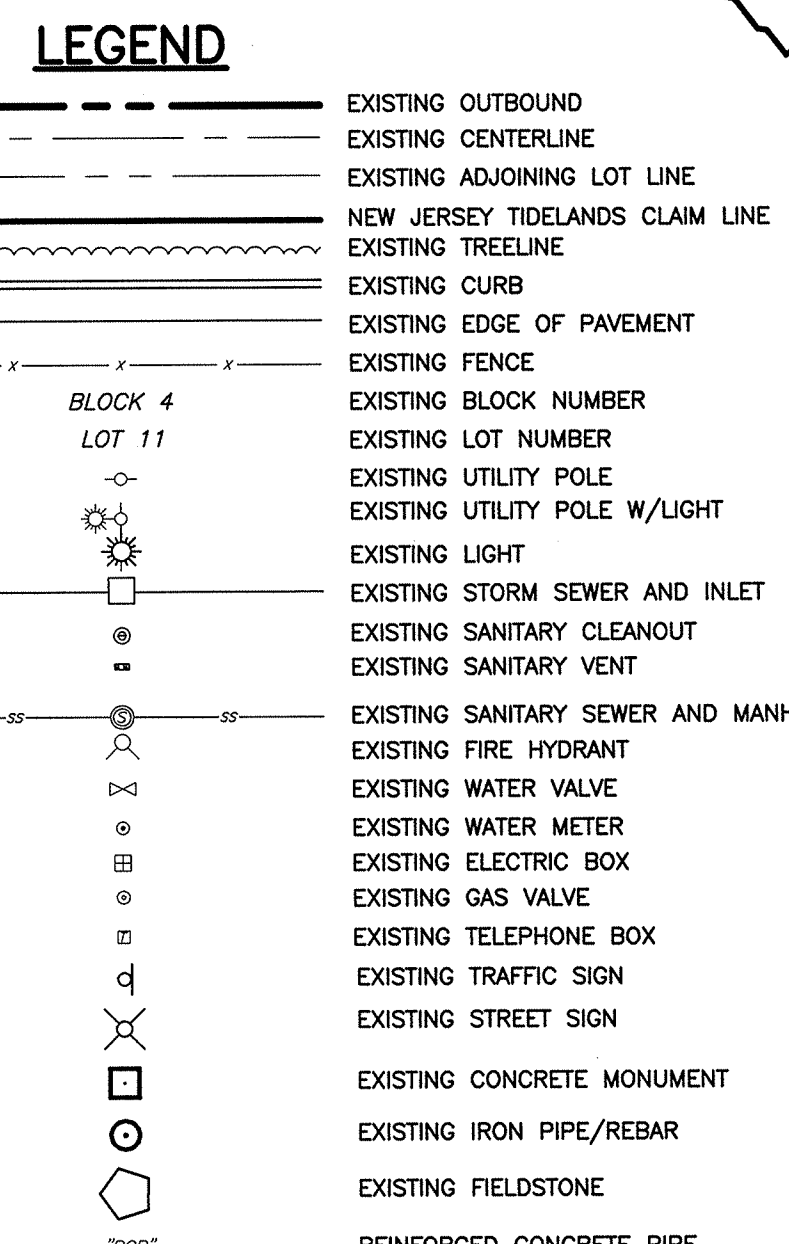
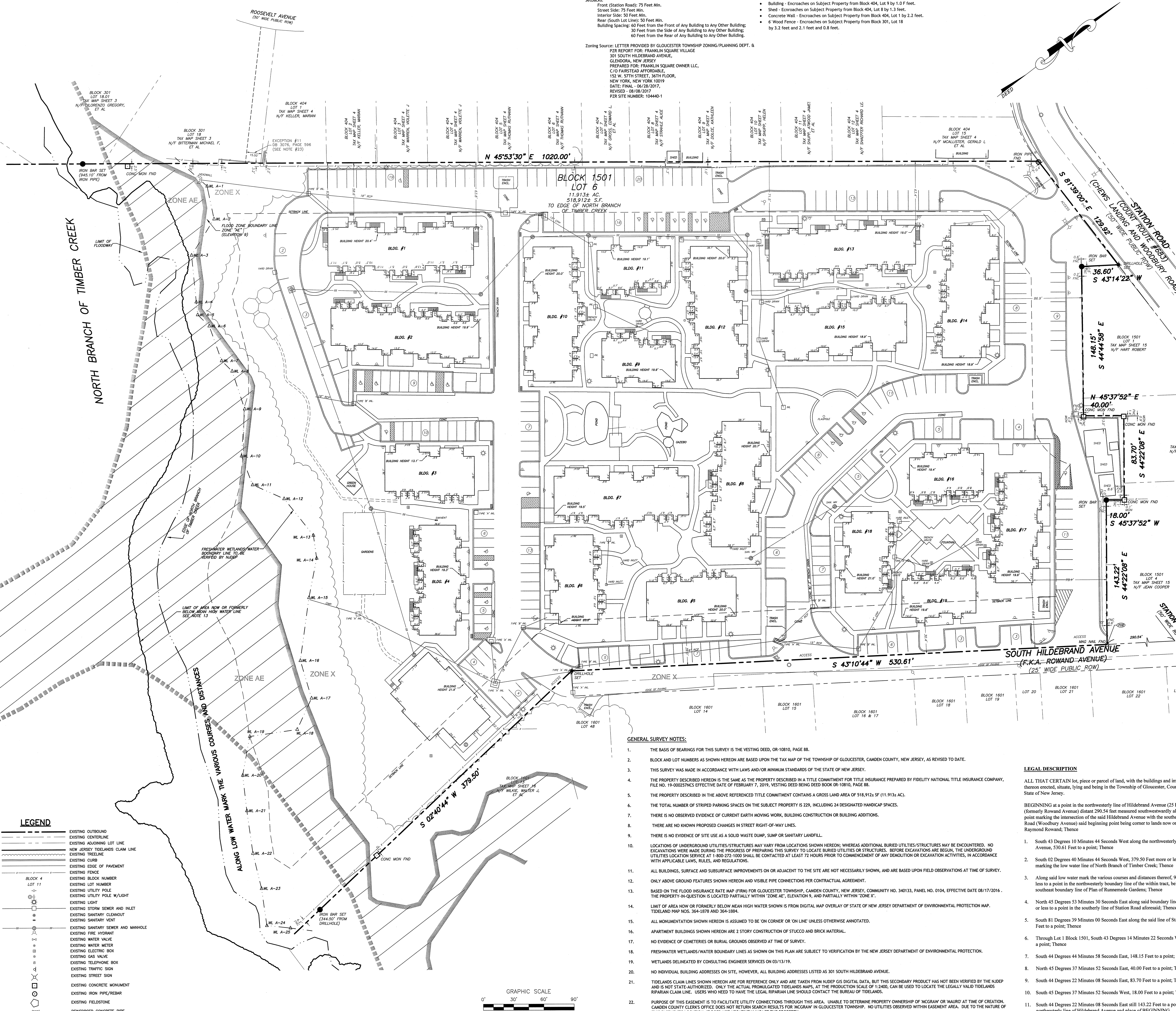

GENERAL SURVEY NOTES:

- 1. THE BASIS OF BEARINGS FOR THIS SURVEY IS THE VESTING DEED, OR-10810, PAGE 88.
2. BLOCK AND LOT NUMBERS AS SHOWN HEREON ARE BASED UPON THE TAX MAP OF THE TOWNSHIP OF GLOUCESTER, CAMDEN COUNTY, NEW JERSEY, AS REVISED TO DATE.
3. THIS SURVEY WAS MADE IN ACCORDANCE WITH LAWS AND/OR MINIMUM STANDARDS OF THE STATE OF NEW JERSEY.
4. THE PROPERTY DESCRIBED HEREON IS THE SAME AS THE PROPERTY DESCRIBED IN A TITLE COMMITMENT FOR TITLE INSURANCE PREPARED BY FIDELITY NATIONAL TITLE INSURANCE COMPANY, FILE NO. 19-000257NCS EFFECTIVE DATE OF FEBRUARY 7, 2019, VESTING DEED BEING DEED BOOK OR-10810, PAGE 88.
5. THE PROPERTY DESCRIBED IN THE ABOVE REFERENCED TITLE COMMITMENT CONTAINS A GROSS LAND AREA OF 518,912.2± S.F. (11.913± AC).
6. THE TOTAL NUMBER OF STRIPED PARKING SPACES ON THE SUBJECT PROPERTY IS 229, INCLUDING 24 DESIGNATED HANDICAP SPACES.
7. THERE IS NO OBSERVED EVIDENCE OF CURRENT EARTH MOVING WORK, BUILDING CONSTRUCTION OR BUILDING ADDITIONS.
8. THERE ARE NO KNOWN PROPOSED CHANGES IN STREET RIGHT-OF-WAY LINES.
9. THERE IS NO EVIDENCE OF SITE USE AS A SOLID WASTE DUMP, SLUMP OR SANITARY LANDFILL.
10. LOCATIONS OF UNDERGROUND UTILITIES/STRUCTURES MAY VARY FROM LOCATIONS SHOWN HEREON; WHEREAS ADDITIONAL BURIED UTILITIES/STRUCTURES MAY BE ENCOUNTERED, NO EXCAVATIONS WERE MADE DURING THE COURSE OF THIS SURVEY TO LOCATE BURIED UTILITIES OR STRUCTURES. BEFORE EXCAVATIONS ARE BEGUN, THE UNDERGROUND UTILITIES LOCATION SERVICE AT 1-800-273-2000 SHALL BE CONTACTED AT LEAST 72 HOURS PRIOR TO COMMENCEMENT OF ANY DEMOLITION OR EXCAVATION ACTIVITIES, IN ACCORDANCE WITH APPLICABLE LAWS, RULES, AND REGULATIONS.
11. ALL BUILDINGS, SURFACE AND SUBSURFACE IMPROVEMENTS ON OR ADJACENT TO THE SITE ARE NOT NECESSARILY SHOWN, AND ARE BASED UPON FIELD OBSERVATIONS AT TIME OF SURVEY. ONLY ABOVE GROUND FEATURES SHOWN HEREON AND VISIBLE PIPE CONNECTIONS PER CONTRACTUAL AGREEMENT.
12. BASED ON THE FLOOD INSURANCE RATE MAP (FIRM) FOR GLOUCESTER TOWNSHIP, CAMDEN COUNTY, NEW JERSEY, COMMUNITY NO. 340133, PANEL NO. 0104, EFFECTIVE DATE 08/17/2016, THE PROPERTY-IN-QUESTION IS LOCATED PARTIALLY WITHIN "ZONE AE", AND PARTIALLY WITHIN "ZONE X".
13. LIMIT OF AREA NOW OR FORMERLY BELOW MEAN HIGH WATER SHOWN IS FROM DIGITAL MAP OVERLAY OF STATE OF NEW JERSEY DEPARTMENT OF ENVIRONMENTAL PROTECTION MAP TIDELAND MAP NOS. 304-1078 AND 304-1084.
14. ALL MONUMENTATION SHOWN HEREON IS ASSUMED TO BE ON CORNER OR ON LINE UNLESS OTHERWISE ANNOTATED.
15. APARTMENT BUILDINGS SHOWN HEREON ARE 2 STORY CONSTRUCTION OF STUCCO AND BRICK MATERIAL.
16. NO EVIDENCE OF CEMETERIES OR BURIAL GROUNDS OBSERVED AT TIME OF SURVEY.
17. FRESHWATER WETLANDS/WATER BOUNDARY LINES AS SHOWN ON THIS PLAN ARE SUBJECT TO VERIFICATION BY THE NEW JERSEY DEPARTMENT OF ENVIRONMENTAL PROTECTION. WETLANDS DELINEATED BY CONSULTING ENGINEER SERVICES ON 02/13/19.
18. NO INDIVIDUAL BUILDING ADDRESSES ON SITE, HOWEVER, ALL BUILDING ADDRESSES LISTED AS 301 SOUTH HILDEBRAND AVENUE.
19. TIDELANDS CLAIM LINES SHOWN HEREON ARE FOR REFERENCE ONLY AND ARE TAKEN FROM NJDEP GIS DIGITAL DATA, BUT THIS SECONDARY PRODUCT HAS NOT BEEN VERIFIED BY THE NJDEP AND IS NOT STATE-AUTHORIZED. ONLY THE ACTUAL PROMULGATED TIDELANDS MAPS, AT THE PRODUCTION SCALE OF 1:2400, CAN BE USED TO LOCATE THE LEGALLY VALID TIDELANDS RIPARIAN CLAIM LINE. USERS WHO NEED TO HAVE THE LEGAL RIPARIAN LINE SHOULD CONTACT THE BUREAU OF TIDELANDS.
20. PURPOSE OF THIS EASEMENT IS TO FACILITATE UTILITY CONNECTIONS THROUGH THIS AREA. UNABLE TO DETERMINE PROPERTY OWNERSHIP OF MCGRAW OR WAURO AT TIME OF CREATION. CAMDEN COUNTY CLERK'S OFFICE DOES NOT RETURN SEARCH RESULTS FOR MCGRAW IN GLOUCESTER TOWNSHIP. NO UTILITIES OBSERVED WITHIN EASEMENT AREA. DUE TO THE NATURE OF THIS EASEMENT'S LOCATION, IT DOES NOT NEGATIVELY IMPACT THE PROPERTY.

LEGAL DESCRIPTION

ALL THAT CERTAIN lot, piece or parcel of land, with the buildings and improvements thereon erected, situate, lying and being in the Township of Gloucester, County of Camden, State of New Jersey:
BEGINNING at a point in the northwesterly line of Hildebrand Avenue (25 Feet Wide); (formerly Rowand Avenue) distant 290.54 feet measured southwestwardly along same from a point marking the intersection of the said Hildebrand Avenue with the southerly line of Station Road (Woodbury Avenue) said beginning point being corner to lands now or formerly of Raymond Rowand; Thence
1. South 43 Degrees 10 Minutes 44 Seconds West along the northwesterly line of Hildebrand Avenue, 530.61 Feet to a point; Thence
2. South 02 Degrees 40 Minutes 44 Seconds West, 379.50 Feet more or less to a point marking the low water line of North Branch of Timber Creek; Thence
3. Along said low water mark the various courses and distances thereof, 950 Feet more or less to a point in the northwesterly boundary line of the within tract, being also the southeast boundary line of Plan of Runnemede Gardens; Thence
4. North 45 Degrees 37 Minutes 52 Seconds East along said boundary line, 1020 Feet more or less to a point in the southerly line of Station Road aforesaid; Thence
5. South 81 Degrees 39 Minutes 00 Seconds East along the said line of Station Road, 129.92 Feet to a point; Thence
6. Through Lot 1 Block 1501, South 43 Degrees 14 Minutes 22 Seconds West, 36.60 Feet to a point; Thence
7. South 44 Degrees 44 Minutes 58 Seconds East, 148.15 Feet to a point; Thence
8. North 45 Degrees 37 Minutes 52 Seconds East, 40.00 Feet to a point; Thence
9. South 44 Degrees 22 Minutes 08 Seconds East, 83.70 Feet to a point; Thence
10. South 45 Degrees 37 Minutes 52 Seconds West, 18.00 Feet to a point; Thence
11. South 44 Degrees 22 Minutes 08 Seconds East still 143.22 Feet to a point in the northwesterly line of Hildebrand Avenue and place of BEGINNING.

I HEREBY CERTIFY TO:
CITIBANK, N.A., ITS SUCCESSORS AND/OR ASSIGNS
U.S. BANK NATIONAL ASSOCIATION, ITS SUCCESSORS AND/OR ASSIGNS
AND/OR ASSIGNS
FEDERAL HOME LOAN MORTGAGE CORPORATION, ITS SUCCESSORS AND/OR ASSIGNS
NEW JERSEY HOME AND MORTGAGE FINANCE AGENCY, ITS SUCCESSORS AND/OR ASSIGNS
FRANKLIN SQUARE PRESERVATION URBAN RENAISSANCE, A NEW JERSEY LIMITED PARTNERSHIP
BRIM 481 HOUSING FUND II LIMITED PARTNERSHIP, A MASSACHUSETTS LIMITED PARTNERSHIP
BRIM SPECIAL LIMITED PARTNER, INC., A FLORIDA CORPORATION, AND EACH OF THEIR RESPECTIVE SUCCESSORS AND ASSIGNS AS THEIR INTERESTS MAY APPEAR.
AND THEIR SUCCESSORS AND/OR ASSIGNS OF THE ORIGINAL MORTGAGE.
THIS IS TO CERTIFY THAT THIS MAP OR PLAN AND THE SURVEY ON WHICH IT IS BASED WERE MADE IN ACCORDANCE WITH THE 2016 MINIMUM STANDARD DETAIL REQUIREMENTS FOR ALTA/NSP LAND TITLE SURVEYS, JOINTLY ESTABLISHED AND ADOPTED BY ALTA AND NSP, AND INCLUDES ITEMS 1, 2, 3, 4, 6, 7A, 7B, 8, 9, 10A, 11, 12, 13, 16, 17, 18, 19 & 20 OF TABLE A THEREOF.
THE FIELD WORK WAS COMPLETED ON 05/10/19. THIS MAP IS DATED 07/29/19
ADAM R. GRANT
PROFESSIONAL LAND SURVEYOR
N.J. LIC. NO. 246504335700

Professional information block including: ALTA/NSP LAND TITLE SURVEY, FRANKLIN SQUARE VILLAGE, 301 SOUTH HILDEBRAND AVENUE, PLATE 15, BLOCK 1501, LOT 6, TOWNSHIP OF GLOUCESTER, CAMDEN COUNTY, NEW JERSEY. Includes the signature of Adam R. Grant, Professional Land Surveyor, and the seal of the Professional Engineers, Planners, & Land Surveyors of New Jersey.

● < 100kW



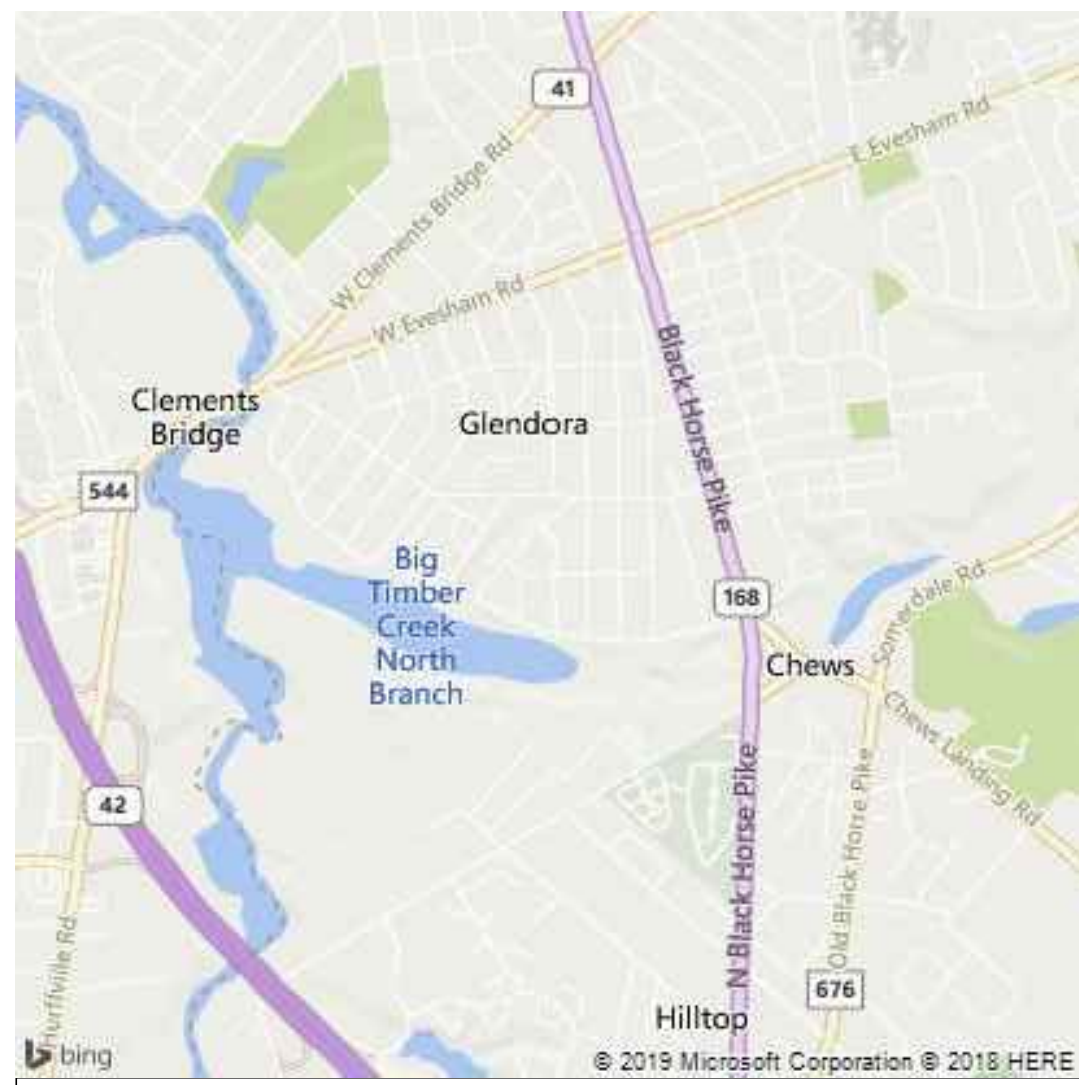

LOCATION MAP:

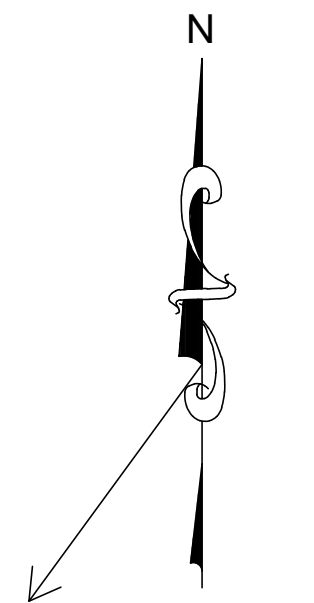

216° MODULE
ORIENTATION
5° TILT



PROJECT DATA

OWNER FRANKLIN SQUARE VILLAGE
301 S. HILDEBRAND AVE.
GLENDDORA, NJ 08029

SOLAR ARRAY: SYSTEM 6 = BLDGS 3, 5, 11, & 20
PANELS: JINKO JKM400M-72H-V
210 PANELS @ 400 WATTS EACH

RACKING: MOUNTED AT 5 DEG ANGLE

INVERTERS: (2) SMA SB7.7
(8) SMA SB6.0

DC SYSTEM RATING: 84,000 W D.C. STC

FRANKLIN SQUARE VILLAGE

84.00-KW DC

63.40-KW DC

NOT FOR CONSTRUCTION

ARC DESIGN

409 NORTH MAIN STREET
ELMER, NEW JERSEY 08318
(856) 712-2166 FAX: (856) 358-1511

PROPOSED PHOTO-VOLTAIC ARRAY

FRANKLIN SQUARE VILLAGE
301 SOUTH HILDEBRAND AVENUE
GLENDDORA, NJ 08029

JAMES A. CLANCY
N.J. PE LICENSE # 33998



REVISIONS

DATE	COMMENT

JOB #	
DRWN	RCA
CHKD	JAC
SCALE	AS NOTED
DATE	08-27-2019

C-1

Interconnection to Utility and System Grounding per NEC-2014 Article 690

Provide signage as req'd by NEC-2014 Article 690.

ALL outdoor equipment shall be a minimum of NEMA-3R rated.

Confirm line side voltage at electric utility service entrance BEFORE connecting inverter and ensure proper operational range required by system inverter.

SYSTEM SIZE = 84,000 W DC
63,400 W AC

24/7 ACCESSIBLE & UTILITY LOCKABLE

PV AC DISCONNECT
400 A RATED
350 A FUSED DISCONNECT
120/240V - 1Ø-3W

TO UTILITY

EXISTING UTILITY TRANSFORMER

ALL EXTERIOR MOUNTED COMBINERS, JUNCTION BOXES, TROUGHS, DISCONNECTS, ETC. SHALL BE MIN. NEMA 3R RATED.

AC & DC GROUNDING CONDUCTORS PER NEC ARTICLE 690.43 (A) thru (F) CONNECTED AS PER 690.45(A), 690.46, & SIZED PER 250.122

DC CONDUITS MAY BE RUN ABOVE OR BELOW ROOF. PROVIDE SOLADECK JUNCTION/FLASHING WHEN PENETRATING THE ROOF WITH DC CONDUCTORS.

-Electrical contractor to verify interconnection requirements with Electrical Utility for connection location and standards.
-Electrical Contractor to provide expansion joints and anchoring of all conduit runs as per NEC requirements.
-Provide label/placard at existing utility connection with "WARNING - CUSTOMER OWNED ELECTRICAL GENERATION EQUIPMENT CONNECTED" with appropriate hazard and output ratings of PV System.

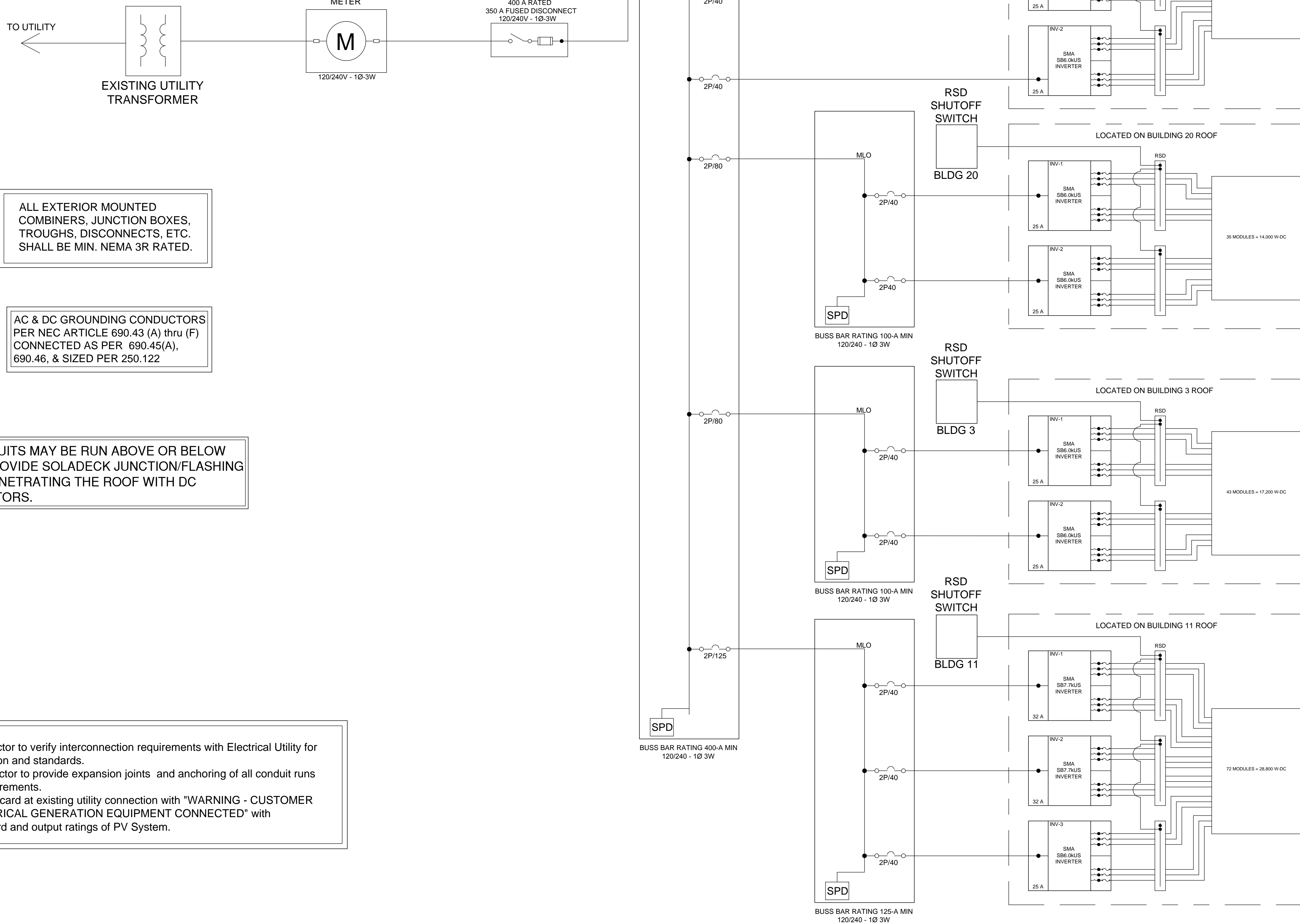

ARC DESIGN

409 NORTH MAIN STREET
ELMER, NEW JERSEY 08318
(856) 712-2166 FAX: (856) 358-1511

PROPOSED PHOTO-VOLTAIC ARRAY

FRANKLIN SQUARE VILLAGE
301 SOUTH HILDEBRAND AVENUE
GLEN DORA, NJ 08029

JAMES A. CLANCY
N.J. PE LICENSE # 33998

REVISIONS

DATE	COMMENT

JOB #	
DRWN	RCA
CHKD	JAC
SCALE	NONE
DATE	08-27-2019

E-1